



# TIP120/121/122 TIP125/126/127

## COMPLEMENTARY SILICON POWER DARLINGTON TRANSISTORS

- STMicroelectronics PREFERRED SALESTYPES

### DESCRIPTION

The TIP120, TIP121 and TIP122 are silicon Epitaxial-Base NPN power transistors in monolithic Darlington configuration mounted in Jedec TO-220 plastic package. They are intended for use in power linear and switching applications. The complementary PNP types are TIP125, TIP126 and TIP127, respectively.

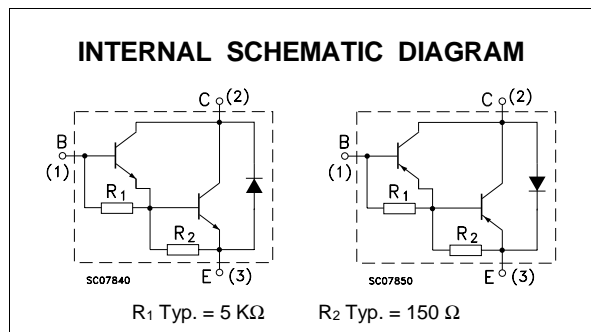
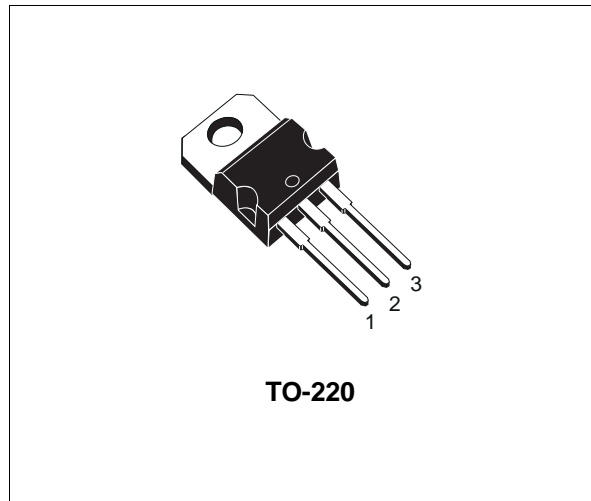

### ABSOLUTE MAXIMUM RATINGS

Symbol	Parameter	Value				Unit
		NPN	TIP120	TIP121	TIP122	
		PNP	TIP125	TIP126	TIP127	
$V_{CBO}$	Collector-Base Voltage ( $I_E = 0$ )		60	80	100	V
$V_{CEO}$	Collector-Emitter Voltage ( $I_B = 0$ )		60	80	100	V
$V_{EBO}$	Emitter-Base Voltage ( $I_C = 0$ )		5			V
$I_C$	Collector Current		5			A
$I_{CM}$	Collector Peak Current		8			A
$I_B$	Base Current		0.1			A
$P_{tot}$	Total Dissipation at $T_{case} \leq 25^\circ C$ $T_{amb} \leq 25^\circ C$		65			W
			2			W
$T_{stg}$	Storage Temperature		-65 to 150			$^\circ C$
$T_j$	Max. Operating Junction Temperature		150			$^\circ C$

\* For PNP types voltage and current values are negative.

## TIP120/TIP121/TIP122/TIP125/TIP126/TIP127

### THERMAL DATA

R <sub>thj-case</sub>	Thermal Resistance Junction-case	Max	1.92	°C/W
R <sub>thj-amb</sub>	Thermal Resistance Junction-ambient	Max	62.5	°C/W

### ELECTRICAL CHARACTERISTICS (T<sub>case</sub> = 25 °C unless otherwise specified)

Symbol	Parameter	Test Conditions	Min.	Typ.	Max.	Unit
I <sub>CEO</sub>	Collector Cut-off Current (I <sub>B</sub> = 0)	for <b>TIP120/125</b> V <sub>CE</sub> = 30 V for <b>TIP121/126</b> V <sub>CE</sub> = 40 V for <b>TIP122/127</b> V <sub>CE</sub> = 50 V			0.5 0.5 0.5	mA mA mA
I <sub>CBO</sub>	Collector Cut-off Current (I <sub>B</sub> = 0)	for <b>TIP120/125</b> V <sub>CB</sub> = 60 V for <b>TIP121/126</b> V <sub>CB</sub> = 80 V for <b>TIP122/127</b> V <sub>CB</sub> = 100 V			0.2 0.2 0.2	mA mA mA
I <sub>EBO</sub>	Emitter Cut-off Current (I <sub>C</sub> = 0)	V <sub>EB</sub> = 5 V			2	mA
V <sub>CEO(sus)</sub> *	Collector-Emitter Sustaining Voltage (I <sub>B</sub> = 0)	I <sub>C</sub> = 30 mA for <b>TIP120/125</b> for <b>TIP121/126</b> for <b>TIP122/127</b>	60 80 100			V V V
V <sub>CE(sat)</sub> *	Collector-Emitter Saturation Voltage	I <sub>C</sub> = 3 A I <sub>B</sub> = 12 mA I <sub>C</sub> = 5 A I <sub>B</sub> = 20 mA			2 4	V V
V <sub>BE(on)</sub> *	Base-Emitter Voltage	I <sub>C</sub> = 3 A V <sub>CE</sub> = 3 V			2.5	V
h <sub>FE</sub> *	DC Current Gain	I <sub>C</sub> = 0.5 A V <sub>CE</sub> = 3 V I <sub>C</sub> = 3 A V <sub>CE</sub> = 3 V	1000 1000			

\* Pulsed: Pulse duration = 300 μs, duty cycle < 2 %  
For PNP types voltage and current values are negative.

**TO-220 MECHANICAL DATA**

DIM.	mm			inch		
	MIN.	TYP.	MAX.	MIN.	TYP.	MAX.
A	4.40		4.60	0.173		0.181
C	1.23		1.32	0.048		0.051
D	2.40		2.72	0.094		0.107
D1		1.27			0.050	
E	0.49		0.70	0.019		0.027
F	0.61		0.88	0.024		0.034
F1	1.14		1.70	0.044		0.067
F2	1.14		1.70	0.044		0.067
G	4.95		5.15	0.194		0.203
G1	2.4		2.7	0.094		0.106
H2	10.0		10.40	0.393		0.409
L2		16.4			0.645	
L4	13.0		14.0	0.511		0.551
L5	2.65		2.95	0.104		0.116
L6	15.25		15.75	0.600		0.620
L7	6.2		6.6	0.244		0.260
L9	3.5		3.93	0.137		0.154
DIA.	3.75		3.85	0.147		0.151

